



Description

Establish on-demand broadband satellite communications virtually anywhere on the globe with the SDR-4000 L-Band Software Defined Radio Terminal. The terminal supports the Inmarsat Broadband Global Network (BGAN), the leading global, mobile commercial broadband satcom service available.

The SDR-4000 L-Band Software Defined Radio Terminal is a COTS platform that offers Beyond-Line-of-Sight (BLOS) communication and system interoperability with the ability to support multiple waveforms including Inmarsat BGAN, APCO P25, FM3TR, WNW OFDM PHY, and more. The SDR-4000 L-Band Software Defined Radio Terminal is fully software-reconfigurable, allowing development effort, cost and risk to be significantly reduced while minimizing and protecting hardware investment.



Key Benefits

- A fully software-defined commercial-off-the-shelf (COTS) platform that supports the Inmarsat BGAN Network
- Supports other SATCOM and terrestrial applications
- Allows for global, on-demand Beyond-Line-of-Sight (BLOS) communication with guaranteed data rates
- Reduce time-to-deployment using a fully configured COTS platform
- Substantially reduce waveform development and porting costs
- Improve system interoperability with a single terminal that supports several communications systems
- Easily integrate with external COTS and custom RF front ends through analog IF interface
- Reduce total cost of ownership by minimizing the need for hardware upgrades and allowing future updates in the field via software
- Other RF interfaces are available on the SDR-4000 platform including APCO P-25, WNW OFDM PHY, FM3TR, SINCGARS, SRW EW PHY, and more

Target Applications

- Commercial Satellite Communications gateways, terminals and hubs
- Military Satellite Communications (MILSATCOM) gateways, terminals and hubs
- Tactical Military Communications (MILCOM) - ground vehicular, airborne, unmanned aerial vehicles (UAV), shipborne
- Satellite backhaul for public safety networks
- VSAT terminal and waveform development

Features

- Utilizes Xilinx® Virtex-4™, Texas Instruments TI DSP and Freescale™ general purpose processing technology
- Separate data path and control bus ideal for wireless modem applications requiring low latency deterministic operation
- External Serial (RS232/422), Gigabit Ethernet, and General Purpose I/O interfaces
- Inmarsat BGAN SDR Waveform is SCA v2.2.2 compliant

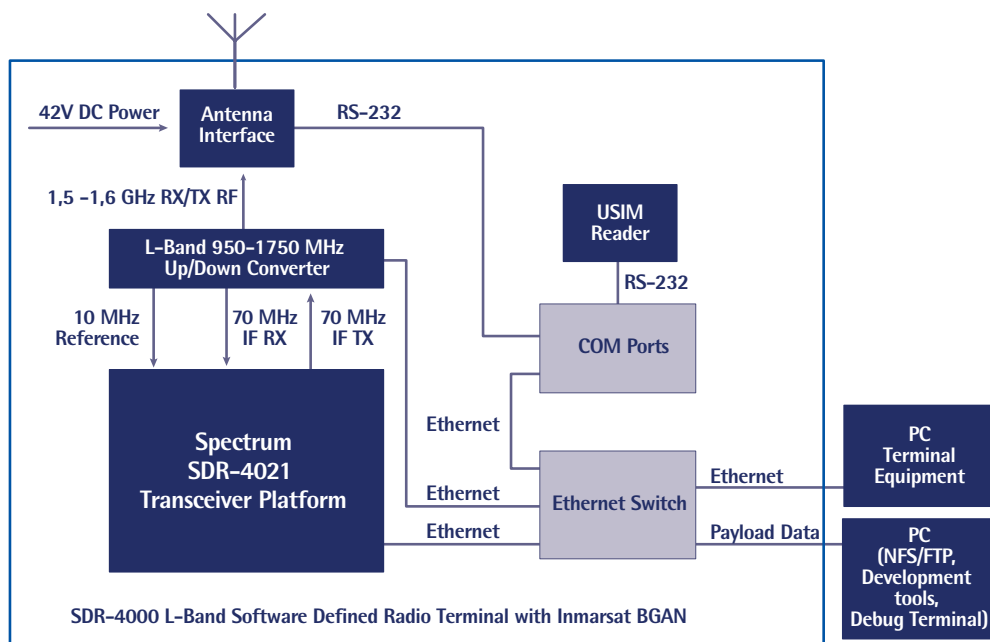

Block Diagram

Specifications

Hardware

[frequency range]	Receive	950-1750 MHz (L-Band)
	Transmit	950-1750 MHz (L-Band)
[antenna]	Type	External
	Connector	BNC
[analog IF]	Frequency	70 MHz IF (standard)
	Connector	1 RX (SSMC), 1 TX (SSMC)
[software reconfigurable modem]		Spectrum's SDR-4021 Software-defined Radio Transceiver For detailed specifications, please see SDR-4000 Value Starter Kit Datasheet
[power input]	Operating	100/220VAC 60/50 Hz
[environmental]	Operating Temperature	0 to 40°C
[mechanical dimensions]		6U high 19" rackmount
	Rugged enclosure exterior	70 cm (w) x 52 cm (h) x 93 cm (d)
[network interface]	Type	Gigabit Ethernet
	Connector	1 RJ-45
[external host]		Windows Laptop (connected via ethernet)
[power input]	Operating	100/220VAC 60/50 Hz

Software

[operating system]		GreenHills® INTEGRITY® RTOS
[development tools]		Xilinx ISE Foundation Texas Instruments Code Composer Studio (DSP) Green Hills® MULTI® (GPP)
[software communications architecture]		See future options section
[Inmarsat BGAN specifications]	Data	Standard IP (TCP) Variable bit rate service, up to 492 kbps (send & receive)
	Streaming	Guaranteed bit rate service, available on demand 32,64,128,256 kbps (send & receive) UDP, ISDN support
	Type Approval Certification	Contact Spectrum sales for information on seeking Type Approval Certification
[other external interfaces]	Serial	RS-232/422
	Analog Input	BNC connector, 50 Ohms
	SIM Card Reader	SmartBee 3,579 MHz Serial RS-232 Programmer
[processing]	GPP	MPC8541
	FPGA	Virtex-4 SX55, LX60
	DSP	C6416T
[future options]	SCA	CRC SCARI++ Core Framework SCA Version 2.2.2
	Ruggedization	Extended temperature range, shock and vibration

The Inmarsat BGAN SDR Waveform is supplied through GateHouse A/S. For more details visit www.gatehouse.dk.