

# ePMC-8120\*

## Xilinx Virtex-II based Processing Engine

ePMC



### Benefits

- Dynamically reconfigurable, high performance parallel processing engine
- Flexible design platform
- Supports implementation of multi-channel, multi-mode receivers for both narrowband and wideband air-interfaces
- *quicComm*<sup>™</sup> software architecture accelerates application development, simplifies the programming model, and ensures code portability

### Applications

- Military communications and military satellite communications including wireless test and measurement, satellite earth station return link
- Signals intelligence including wireless surveillance, signal monitoring, array antenna applications such as direction finding and co-channel interference mitigation

### Features

- Single-width Solano-based Enhanced PMC (ePMC) form factor
- Large data buffering capability
- High-speed, low latency, deterministic data paths to carrier board
- Xilinx<sup>®</sup> Virtex-II FPGA device providing up to 6 million system gates
- 512 MB double data rate SDRAM
- High-speed mezzanine interface based on the Solano<sup>®</sup> Communications IC
- Modular front-panel I/O interface module (patent pending), supporting a variety of I/O formats
- 32-bit/33 MHz PCI host bus interface
- JTAG connector compatible with Xilinx ChipScope<sup>™</sup> debugger

### Description

The ePMC-8120 is intended for use as a front-end signal processing engine, or a general-purpose fixed-point or floating-point co-processor. The ePMC-8120 is a single-width ePMC module, 32-bit/33 MHz PCI device capable of operating in a master or slave mode, with PCI burst DMA capability. The ePMC-8120 is equipped with a modular front panel to support a variety of I/O formats. It incorporates a single Xilinx Virtex-II XC2V6000 FPGA for processing, as well as multiple output paths. A high-speed interface to the carrier board can be established via the Solano Communication ICs. The module features two Double Data Rate (DDR) SDRAM banks with 512 MB total capacity.

The ePMC standard adds the power of the Solano Communications IC to the PCI bus of the PMC standard. The addition of these high-speed communication channels enables eight links at 213 MB/s full-duplex of data throughput each, directly from the mezzanine to the processing engine.



\* For new designs, we recommend one of this module's successor products: XMC-8131, XMC-1131, or XMC-2131. For more information, please visit [www.spectrumsignal.com/products/hcdr](http://www.spectrumsignal.com/products/hcdr) or contact Spectrum Sales.

## Block Diagram

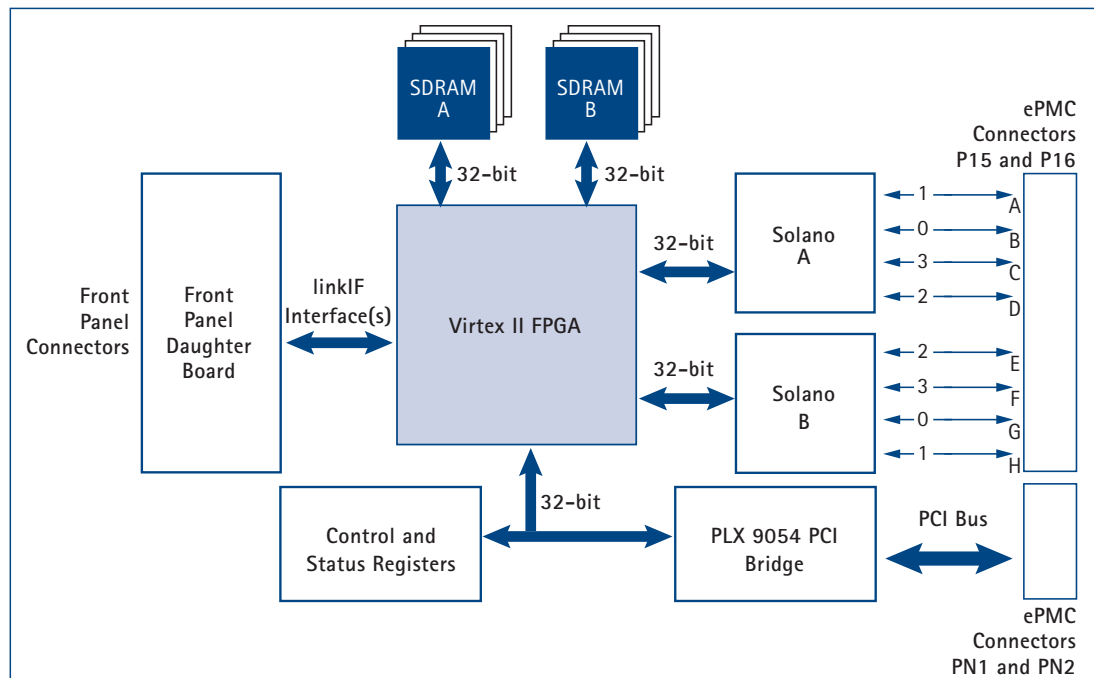

## Architecture

The ePMC-8120 has one Xilinx Virtex-II XC2V6000 FPGA as the standard offering. The XC2V3000 version is available upon request. Two banks with a total of 512 MB of DDR (Dual Data Rate) SDRAM are provided for local buffering. The ePMC-8120 utilizes Spectrum's Solano Communications IC to provide up to eight 213 MB/s full-duplex, low latency, communications paths to Spectrum's signal processing engines.

The ePMC-8120 PCI interface is implemented with a PLX9054 32-bit/33 MHz I/O accelerator. This PCI bridge technology is able to operate in a master or slave mode, and supports PCI burst DMA transfers. The PCI bridge directly interfaces with the FPGA device in the system to allow configuration, command, and control of these devices over the PCI bus.

### [ Solano Communications IC ]

The Solano Communications IC provides high bandwidth data paths between ePMC mezzanine modules and ePMC carriers. A Solano has four high-speed LVDS links each capable of 213 MB/s full-duplex communications. Each node has two Solano ICs, providing an aggregate bandwidth of 1.7 GB/s. A data network implemented using this IC provides system throughput that can be many times higher than that offered by conventional based or serial link architectures.

### [ Xilinx Virtex-II FPGA ]

With densities ranging from 40,000 up to 8 million system gates, the Virtex-II platform FPGA combines a large amount of programmable logic, advanced clocking circuitry, and embedded memory with versatile, fast interconnect structures. Virtex-II FPGAs provide a single platform that is easily customizable for system connectivity, DSP and/or data processing applications.

## [ Interfaces ]

The ePMC-8120 incorporates a modular I/O front-panel (patent pending) supporting access in a variety of formats. The standard I/O front-panel module supports linkIF, a high-speed digital interface. A synchronization connector is also available to allow multiple modules to maintain synchronous operation for coherent applications such as beam forming and direction finding. The linkIF front-panel interface is pin compatible with Spectrum's ePMC-2ADC dual input 14-bit, 80 MSPS A/D module. The ePMC-8120 is capable of receiving up to four 80 MSPS digital IF (intermediate frequency) channels.

The ePMC-8120 is compatible with Spectrum's PRO-1900/1901 ePMC carrier boards and standard PMC modules, equipping users with a powerful versatile platform that is suitable for a wide variety of applications.

## Software

### [ quicComm Software Development Kit (SDK) ]

quicComm software equips users with basic link level access and control of Spectrum's flexComm™ products. quicComm significantly accelerates user application development. It is also standard across all flexComm products, allowing code portability. This software includes a board support package for control and data handling which:

- Allows configuration and control of the Solano~links and the ePMC modules
- Initiates and manages data transfers
- Manages interrupts
- Enables dynamic loading on a processor without affecting other processors

The supplied FPGA Wrapper, abstracts all board level glue logic, such as linkIF, Solano, PCI interfaces and memory controllers on the module. The Wrapper is designed so users can expedite the integration of third-party or custom cores into the ePMC-8120 module.

### [ Xilinx's ISE Foundation ]

ISE Foundation is an integrated programmable logic design environment. It includes: schematic capture, power analysis tools, physical synthesis for FPGAs, advanced Place and Route Algorithms, HDL Advisors, and Timing Cross-Probing.

ISE Foundation also contains COREgenerator, a graphical interactive design entry tool that is used to create high-level modules. COREgenerator gives access to a library of hundreds of FPGA IP cores, many of them free, from Xilinx and third-party vendors. This library includes DSP applications such as, digital down converters (DDC), direct digital synthesizers (DDS), FIR filters, FFT, numerically controlled oscillator (NCO), memory controller, etc.

Please note that Spectrum routinely develops custom cores for clients. If you have such a requirement, please contact Spectrum Sales.

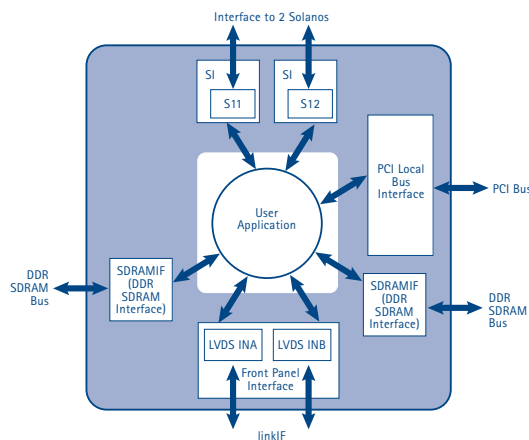

ePMC-8120 FPGA Wrapper

## Specifications

[ general ]	FPGA Device	Xilinx Virtex-II XC2V6000 (XC2V3000 available on request)
	Clock	On-board 50 MHz clock generator
[ buses ]	Host	32-bit/33 MHz PCI Bus Interface
[ external interfaces ]	PCI Interface	PLX9054 32-bit, 33 MHz PCI I/O accelerator
	linkIF	48-bit LVDS high-speed user-changeable front-panel interface, compatible with Spectrum's ePMC-2ADC, and ePMC-32MSDDC modules
	JTAG Connection ePMC Interface	JTAG connector for Virtex-II FPGA, Xilinx ChipScope™ debugger compatible Eight Spectrum Solano~links, each providing 213 MB/s (full-duplex)
[ compatibility ]	Carrier Compatibility	PRO-1900/PRO-1901 carriers (other carriers contact Spectrum Sales)
	Operating System	Refer to carrier specifications
[ development software ]	Application Libraries	quicComm Software Development Kit
	Example Code	Example code provides a starting point for rapid software prototyping
[ other software ]	FPGA Code Development	ISE Foundation tools from Xilinx is required Synplify Synthesis® from Synplicity and ModelSim® from Model Technology are recommended for FPGA code design
	FPGA	Cores A variety of FPGA cores are available from Xilinx and other third-party vendors
[ electrical ]	Power	Supply Voltage +5V, 3.3V +5/-3% (supplied by PMC connector)
	Current Consumption	Maximum: 0.6A at +3.3V and 3.2A at +5V
[ mechanical ]	Size	149 mm (height) x 74 mm (width)
	Modules (without heatsink)	Single-width form factor in compliance with IEEE P1386.1 PMC Standard
[ environmental ]	Temperature	Operating temperature range of 0 to 50°C with minimal 220 ft/min forced airflow
	RoHS	0 of 6 compliant For other RoHS options, please contact Spectrum Sales
[ ordering information ]		For new designs, we recommend one of this module's successor products: XMC-8131, XMC-1131, or XMC-2131. For more information, please visit <a href="http://www.spectrumsignal.com/products/hcdr">www.spectrumsignal.com/products/hcdr</a> or contact Spectrum Sales.
	100-00493	HCDR-10XX SDK
	650-00115	ePMC-8120-XC2V6000 4-IN LVDS with Interconnect Modules (ICM)
	650-00129	ePMC-8120-XC2V6000 2-IN/2-OUT
	202-00161	LVDS I/O Cable Kit
[ custom configurations ]		For custom configuration options, please contact Spectrum Sales