

Benefits

- High-performance floating-point processing engine
- High-speed, low latency, deterministic data paths to the carrier board
- Supports dynamic task loading on individual processors
- Modular architecture supports rapid scalability, flexible system configurations, and simplifies processor upgrades
- Extensive software support simplifies application development, speeds time-to-market, and ensures code portability

Applications

- Military communications and military satellite communications including satellite earth station return link and wireless prototyping
- Signals intelligence including wireless surveillance, direction finding and wideband analysis

Features

- Two G4 PowerPC MPC7410 processors up to 500 MHz, with 128-bit AltiVec support for floating-point applications
- High-speed communications paths to the carrier, based on the Solano™ Communications IC, support 3.2 GB/s (peak) transfers
- 512 MB of SDRAM
- 2 MB of L2 Cache per MPC7410
- Sustained I/O bandwidth of 430 MB/s on the 60x bus
- Individual on-the-fly reset of each processor through software control
- 32-bit, 33 MHz PCI interface
- Software support includes *quicComm*™, *quicWave*™ for PowerPC, VxWorks 5.5.1®/Tornado II® (2.2.1), CORBA (TAO ORB), and optimized VSIPL libraries

Description

The *flexComm*™ ePMC-PPC module is a dual node G4 PowerPC module that provides exceptional processing power for a wide range of applications in a small, enhanced PMC form factor. The enhanced PMC (ePMC) standard is fully compatible with the IEEE P1386.1 PMC standard but offers the additional benefit of dedicated Solano~links between ePMC compliant carriers and mezzanine modules. The Solano~links provide high-speed, low latency data paths between the carrier and the mezzanine, overcoming the limitations of the PCI bus for high-speed, deterministic data movement, allowing you to access the full power of the PowerPCs without being restricted by an I/O bottleneck.

The ePMC-PPC module excels in any application requiring high-performance data transfers and the exceptional floating-point performance of the AltiVec engine.

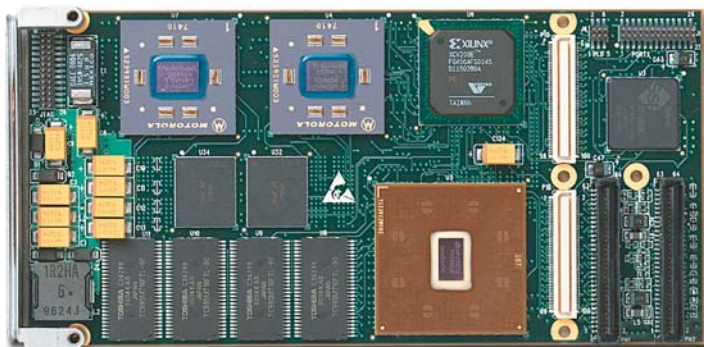

ePMC-PPC Block Diagram

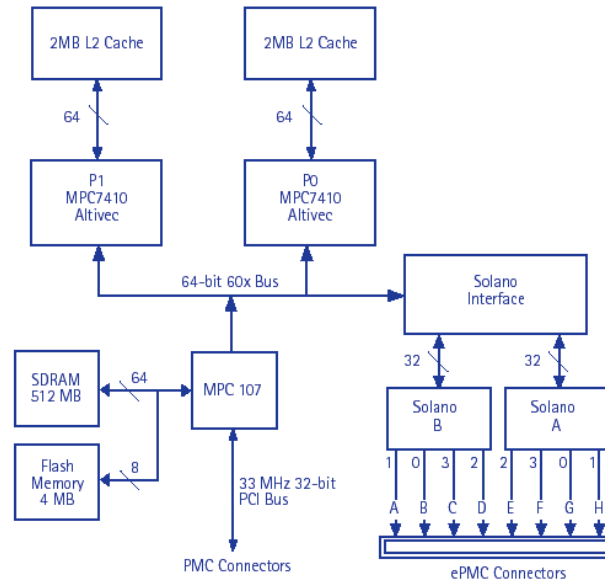

Architecture

The ePMC-PPC architecture is centered around the 60x bus. The 60x bus is a 100 MHz, 64-bit bus capable of sustaining transfers of 430 MB/s between a 60x bus master and SDRAM. Both processors and the Solano Interface can master the 60x bus to effect high-speed data transfers to and from SDRAM to the processors and across the eight Solano~links.

[Processing Nodes]

The ePMC-PPC module has two processing nodes, each consisting of:

- A Motorola G4 MPC7410 processor up to 500 MHz. The MPC7410 is a high-performance, low-power, 32-bit implementation of the PowerPC RISC architecture combined with a full 128-bit implementation of Motorola's AltiVec technology.
- 2 MB of backside L2 Cache

Each processing node can be individually reset on-the-fly via software to support dynamic task loading applications.

[MPC107 Bridge]

The MPC107 PCI Bridge and Integrated Memory Controller provides a bridge between the PCI bus and the 60x bus. The MPC107 also provides many of the other necessities for embedded applications including a high-performance memory controller, dual processor support, 2-channel flexible DMA controller, interrupt controller, I 2 O-ready message unit, inter-integrated circuit controller (I2C), and low skew clock drivers.

[Solano Interface and the Solano Communications IC]

The Solano Communications IC provides high bandwidth data paths between ePMC mezzanine modules and ePMC carriers. The two Solano ICs on the ePMC-PPC provide eight high-speed linkIF (LVDS) links each capable of over 200 MB/s full-duplex for aggregate peak bandwidth of over 1.6 GB/s full-duplex.

The Solano Interface can master the 60x bus to provide sustained transfers of 430 MB/s between the eight Solano~links and SDRAM memory. This architecture provides throughput many times higher than conventional based or serial link architectures and gives the ePMC-PPC module the highest I/O bandwidth in the industry.

"Each Solano provides four 200 MB/s full-duplex links"



[SDRAM]

The ePMC-PPC module has 512 MB of 100 MHz SDRAM on board that is shared by the MPC7410s and is accessed from the PCI and 60x buses through the MPC107.

[Flash]

The ePMC-PPC has a 4 MB Flash memory that stores processor boot code and Solano Interface FPGA configuration data. On power-up, processor P0 boots from Flash, configures the MPC107, loads the Solano Interface FPGA, and then boots processor P1. Both processors then wait for application code to be loaded into SDRAM from the system host. When one of the processors is later reset via software control, it will boot from SDRAM instead of Flash.

Software

[Tornado II and the VxWorks RTOS]

The ePMC-PPC supports Tornado II (2.2.1), the development toolset for the VxWorks 5.5.1 real-time operating system (RTOS) that runs on the ePMC-PPC. The Board Support Package (BSP) for the ePMC-PPC is fully compatible with Tornado II and its associated tools. You can purchase Tornado II and VxWorks 5.5.1 from Spectrum to facilitate one-stop shopping, and avoid any potential configuration problems.

[quicComm Software Development Kit (SDK)]

quicComm software equips users with basic link level access and control of Spectrum's *flexComm* products. The *quicComm* API is standard across all Spectrum products, which simplifies the programming model and ensures code portability to protect your investment in software development. *quicComm* software provides a mechanism for control and data handling which:

- Allows configuration and control of the Solano~links
- Initiates and manages high-performance data transfers, offering near hardware-level performance without the overhead of networking protocols
- Manages interrupts
- Provides numerous examples that serve as a starting point for application development

[quicWave for PowerPC Component Library]

quicWave for PowerPC is a library of building blocks for the development of wireless applications. These building blocks can be combined with user-defined and other *quicWave* blocks to create complete wireless applications. *quicWave* for PowerPC is built on top of the VSIPL industry standard interface for signal processing functionality. This allows the library to be optimized to the PowerPC G4 AltiVec engine simply by linking with Verari Systems™ VSI/Pro® library, also available from Spectrum.

[VSI/Pro]

Verari Systems VSI/Pro is a VSIPL compliant library for signal processing applications. It is ideal for applications such as wireless air-interface processing, radar/sonar processing, and image processing. The VSIPL standard enhances the portability of your signal processing applications by standardizing the interface to signal processing functions.

[CORBA via the TAO ORB]

Spectrum provides CORBA support via the TAO open-source ORB. CORBA provides an industry standard model for distributed computing, and is a requirement in SCA-compliant software radios.

Specifications

[general]	Processors	Two MPC7410 processors, clocked at up to 500 MHz
	Level 2	Cache 2 MB at 200 MHz
	SDRAM	512 MB running at 100 MHz
	Flash	4 MB
[buses]	60x	64-bit, 100 MHz capable of 430 MB/s sustained transfers, higher peak rates Both processors and the Solano Interface can master the 60x bus
[external interfaces]	Solano	Eight Solano~links to the carrier, each capable of over 200 MB/s full-duplex between the ePMC connectors and the Solano Communications ICs
	PCI	32-bit, 33 MHz PCI interface from the MPC107 to the PMC connectors, capable of 132 MB/s peak
	JTAG Connection	Available for debug support via a 2x13 pin header
[development software]	<i>quicComm</i>	<i>quicComm</i> provides functions for: <ul style="list-style-type: none"> • Configuration and control of the Solano~links • High-speed data transfers across the Solano~links • Initiating PCI data transfers It also provides examples to do the following <ul style="list-style-type: none"> • Setup and initiate Solano~link data transfers • Demonstrate carrier-to-module interrupts • Demonstrate interprocessor interrupts
	VxWorks BSP	A VxWorks Board Support Package is provided with support for VxWorks 5.5.1 and Tornado II (2.2.1)
	CORBA (TAO ORB)	The TAO ORB is provided with the SDK for the ePMC-PPC
[other software]	<i>quicWave</i> for PowerPC VxWorks/Tornado	See <i>quicWave</i> for PowerPC datasheet for more details In addition to providing a VxWorks BSP, Spectrum can also provide VxWorks 5.5.1, Tornado II (2.2.1), and all of the relevant project licenses from WindRiver. Contact Spectrum Sales for more details.
	VSI/Pro	Spectrum re-sells Verari Systems VSI/Pro VSIPL compliant library, optimized for the PowerPC Altivec engine.
[electrical]	Supply Voltage (DC)	Power Supply Voltage +5V \pm 5% and +3.3V \pm 5% (supplied by the PMC connectors)
	Current Consumption	Varies by configuration and software load. The following values are typical: <ul style="list-style-type: none"> • 2 A at +5 V and 2.5 A at +3 V for single processor boards • 3.5 A at +5 V and 1.5 A at +3 V for dual processor boards
[mechanical]	Size	149 mm (height) x 74 mm (width) Single-width form factor in compliance with IEEE P1386.1 PMC Standard
[environmental]	Operating Temperature	Operating temperature range of 0 to 45° C
	RoHS	5 of 6 compliant (Pb solder exemption) version available as of April 2007. For RoHS ordering information, other RoHS compliance options or certificates of compliance, please contact Spectrum Sales
[ordering information]		For use on the PRO-1900
	100-00493	HCDR-10XX SDK
	650-00137	ePMC-PPC 2H5 2X(MPC7410/450 MHz 2/200) 512 MB For use on the PRO-3500
	650-00139	ePMC-PPC 2S5 2X(MPC7410/450 MHz 2/200) 512 MB
[other configurations]		Please contact Spectrum Sales regarding any custom configurations or to purchase additional software items such as <i>quicWave</i> , VSI/Pro, and VxWorks 5.5.1/Tornado II (2.2.1).